

# Potential Benefits of Discrete-Time Controller-based Treatments over Protocol-based Cancer Therapies

**Johanna Sápi, Dániel András Drexler, Levente Kovács**

Research and Innovation Center of Óbuda University, Physiological Controls Group, Óbuda University, Kiscelli utca 82, H-1032 Budapest, Hungary  
{sapi.johanna, drexler.daniel, kovacs.levente}@nik.uni-obuda.hu

---

*Abstract: In medical practice, the effectiveness of fighting cancer is not only determined by the composition of the used drug, but determined by the administration method as well. As a result, having drugs with a suitable action profile is just a promising beginning, but without appropriate delivery methods, the therapy still can be ineffective. Finding the optimal biologic dose is an empirical process in medical practice; however, using controllers, an automated optimal administration can be determined. In this paper, we evaluate the effectiveness of different drug delivery protocols; using in silico simulations (like bolus doses, low-dose metronomic regimen and continuous infusion therapy). In addition, we compare these results with discrete-time controller-based treatments containing state feedback, setpoint control, actual state observer and load estimation.*

*Keywords: antiangiogenic therapy; maximum tolerated dose; bolus dose; low-dose metronomic regimen; continuous infusion therapy; optimal biologic dose; discrete-time control; state feedback; setpoint control; actual state observer; load estimation*

---

## 1 Introduction

### 1.1 Biomedical Background

Tumor cells can appear in the human body after a somatic mutation. As tumor cells proliferate, the number of cells increase, and the tumor volume grows. This growth, however, is limited since blood supply is provided by the nearby capillaries, and if the tumor cells grow farther than the diffusion distance (150  $\mu\text{m}$ ), nutrition and oxygen access decrease. In order to overcome this problem, tumor cells need their own blood supply. There are two main ways to form new blood vessels. The formation of the first primitive vascular plexus is called vasculogenesis, while the formation of new blood vessels from the preexisting

microvasculature is angiogenesis [1]. In the case of tumor growth, angiogenesis takes place, which is regulated by pro- and antiangiogenic factors. The most important proangiogenic factor is the vascular endothelial growth factor (VEGF) since it specifically regulates endothelial proliferation [2] which is essential for angiogenesis. Therefore, VEGF inhibition is an important therapeutic target [3]; and to control angiogenesis, anti-VEGF agents and other VEGF inhibitors are being used around the world [4]. However, the best angiogenic inhibition administration method is still unknown in clinical practice [5], thus an effective and automatic administration method is required.

## 1.2 Background of the Control Problem

We investigated a well-known tumor growth model under antiangiogenic therapy [6] and designed several continuous-time controllers like an LQ control method and state observer [7-9], flat control [10-12], modern robust control method [13-15], feedback linearization method [16] and adaptive fuzzy techniques [17]. However, with the current scientific knowledge, there is no medical device which can handle continuous infusion cancer therapy [18]; hence we designed a discrete-time control herein.

## 2 Tumor Growth Model

P. Hahnfeldt *et al.* created a model which describes tumor growth under angiogenic inhibition [6]. Assuming that after the injection, the level of the inhibitor in the bloodstream is equal to the amount of the injected inhibitor, the original third-order system was modified to a second-order system:

$$\dot{x}_1 = -\lambda_1 x_1 \ln\left(\frac{x_1}{x_2}\right) \quad (1)$$

$$\dot{x}_2 = bx_1 - dx_1^{2/3} x_2 - ex_2 g \quad (2)$$

$$y = x_1, \quad (3)$$

where the first state variable ( $x_1$ ) is the tumor volume [ $\text{mm}^3$ ], while the second state variable ( $x_2$ ) is the volume of the vasculature of the tumor [ $\text{mm}^3$ ]. The input of the model is the concentration of the injected inhibitor ( $g$  [ $\text{mg/kg}$ ]). The first equation contains the  $\lambda_1$  parameter which describes the tumor growth rate (1/day). The change of the vasculature volume depends on three effects: a) the tumor can stimulate the already existing capillaries to form new blood vessels by the process of sprouting (parameter  $b$  [1/day]), b) endothelial cell death causes volume loss in vasculature (parameter  $d$  [1/(day· $\text{mm}^2$ )]), c) the administration of antiangiogenic

drug causes volume loss in vasculature as well (parameter  $e$  [kg/(day·mg)]). In the case of Lewis lung carcinoma, and using endostatin as antiangiogenic drug, the parameters are the following [1]:  $\lambda_1 = 0.192$  1/day,  $b = 5.85$  1/day,  $d = 0.00873$  1/day·mm<sup>2</sup>,  $e = 0.66$  kg/(day·mg).

### 3 Protocol-based Cancer Therapies

#### 3.1 Cancer Protocols in the Light of the Dosage Problem

As it was discussed previously, there is no best way for antiangiogenic drug administration in clinical practice. There are three main methods which are used; however, both ones have advantages and disadvantages. Bolus dose (BD) administration means that the patient receives drug boluses on given days, and between the injections, the treatment has rest periods when there is no drug administration at all. The amount of injected dose can be the Maximum Tolerated Dose (MTD) or any lower dose. After an MTD injection, the treatment should include an extended rest period in order to avoid adverse events. Instead of bolus doses, anticancer drugs can be delivered over prolonged periods using low-doses, this therapy is called as Low-Dose Metronomic (LDM) regimen. Of course, in this case the rest periods can be shorter; but the real question is to find the Optimal Biologic Dose (OBD) which results in the best therapeutic efficacy. Finally, in clinical environment continuous infusion therapy is feasible (e.g. using mini-osmotic pumps), but there is no portable device yet. Clinical experiments have shown that low-dose administration therapies have better therapeutic efficacy than bolus dose injections, and continuous infusion therapies have even better results [19].

#### 3.2 Simulation Results of the Protocol-based Cancer Therapies

The effect of bolus dose administration, low-dose metronomic regimen and continuous infusion therapy was investigated *in silico*, using the modified Hahnfeldt-model described by Eq. (1)-(3). The total administered inhibitor concentration is 300 mg/kg, and treatment period is 15 days in every simulation, in order to get comparable results. Simulations start from the lethal steady-state of the model when the initial value of tumor volume ( $x_1(0)$ ) and vascular volume ( $x_2(0)$ ) are  $1.734 \cdot 10^4$  mm<sup>3</sup>. Four different scenarios were examined [20] (left side of Figure 1).

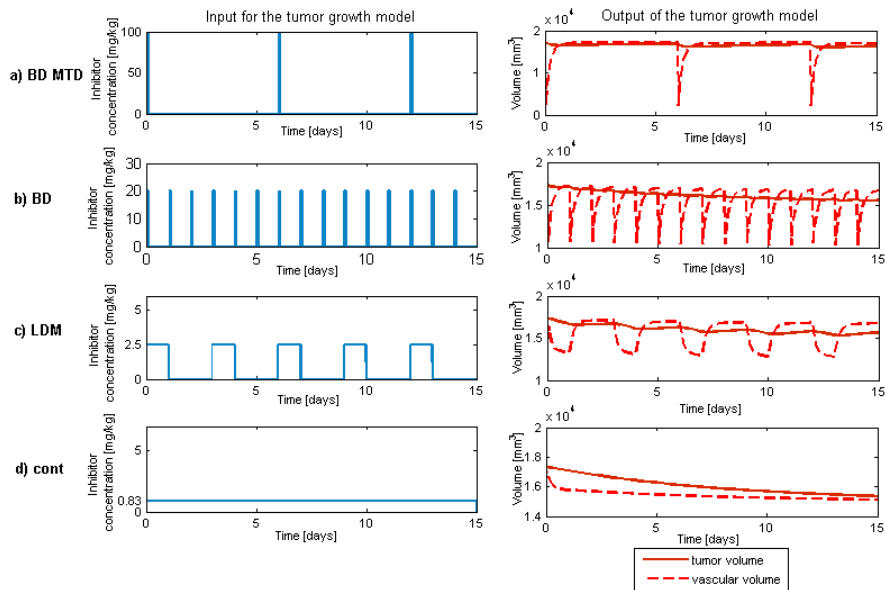

Figure 1

Protocol based therapies (treatment period is 15 days)

*a) Therapy P1: bolus doses with maximum tolerated dose (BD MTD)*

Therapy: 100 mg/kg bolus injected for one hour; treatment days: 1<sup>st</sup>, 6<sup>th</sup> and 12<sup>th</sup> days; rest periods: 5 days. Total inhibitor concentration: 300 mg/kg, steady state tumour volume: 16330 mm<sup>3</sup>.

*b) Therapy P2: bolus doses (BD)*

Therapy: 20 mg/kg bolus injected for one hour; treatment days: every day of the therapy; rest periods: 23 hours. Total inhibitor concentration: 300 mg/kg, steady state tumour volume: 15580 mm<sup>3</sup>.

*c) Therapy P3: low-dose metronomic regimen (LDM)*

Therapy: 2.5 mg/kg infusion administered for one day; treatment days: 1<sup>st</sup>, 4<sup>th</sup>, 7<sup>th</sup>, 10<sup>th</sup>, 13<sup>th</sup> days; rest periods: 2 days. Total inhibitor concentration: 300 mg/kg, steady state tumour volume: 15660 mm<sup>3</sup>.

*d) Therapy P4: continuous infusion therapy (cont)*

Therapy: 0.8333 mg/kg/h continuous infusion administration during the whole therapy; without rest periods. Total inhibitor concentration: 300 mg/kg, steady state tumour volume: 15360 mm<sup>3</sup>.

*Therapy P1 (BD MTD).* The therapy using bolus doses with maximum tolerated dose contains 100 mg/kg boluses which are injected for one hour. Treatment days are the 1<sup>st</sup>, 6<sup>th</sup> and 12<sup>th</sup> days (3 times); between these days, the therapy contains 5 days long rest periods.

*Therapy P2 (BD).* In this case lower bolus doses are used than the maximum tolerated dose. 20 mg/kg bolus is injected for one hour every day of the therapy (15 times). The treatment contains 23 hour rest periods.

*Therapy P3 (LDM).* Low-dose metronomic regimen is carried out with 2.5 mg/kg infusions which are administered for one day. Treatment days are the 1<sup>st</sup>, 4<sup>th</sup>, 7<sup>th</sup>, 10<sup>th</sup> and 13<sup>th</sup> days (5 times). The therapy contains 2 day rest periods.

*Therapy P4 (cont).* Continuous infusion therapy is carried out with 0.8333 mg/kg/h continuous infusion during the whole treatment, without rest periods.

The right side of Figure 1 depicts the outputs of the tumor growth model, using *Therapy P1 - Therapy P4* as inputs. Similarly to the clinical experimental results, simulations show that the less effective therapy is the bolus doses with maximum tolerated dose (BD MTD). Tumor volume reduction is not effective (steady state tumor volume is 16330 mm<sup>3</sup>), and beside this, side-effects can occur and quality of life (QoL) of the patient decreases due to the therapy. Lower bolus doses (BD) cause continuous slight reduction of the tumor volume, however this is not significant (steady state tumor volume is 15580 mm<sup>3</sup>). Another disadvantage of this method is the resulting high frequency oscillation-like characteristics of the vascular volume. Low-dose metronomic administration (LDM) has similar results as BD in terms of tumor volume reduction (steady state tumor volume is 15660 mm<sup>3</sup>) and oscillation-like characteristics of the vascular volume; however, the oscillation frequency and amplitude are lower which can be more tolerable for the patient. The most effective treatment is the continuous infusion therapy (cont) since it results in the lower steady state tumor volume (15360 mm<sup>3</sup>) and the change of the vascular volume is a smooth curve. In addition, due to the extremely low dosage, continuous infusion therapy has virtually no side-effects.

## 4 Discrete-Time Controller-based Treatments

The modified Hahnfeldt-model describes a nonlinear system, which has to be linearized due to controller design aspects. We applied operating point linearization in the  $g_0 = 0$  operating point. The resulting LTI (linear time invariant) system using state space representation is

$$\dot{x} = Ax + Bu \quad (4)$$

$$y = Cx + Du, \quad (5)$$

where the matrices are

$$A = \begin{bmatrix} -\lambda_1 \log\left(\frac{x_1}{x_2}\right) - \lambda_1 & \lambda_1 \frac{x_1}{x_2} \\ b - \frac{2}{3}d \cdot x_1^{-\frac{1}{3}} \cdot x_2 & -d \cdot x_1^{\frac{2}{3}} \end{bmatrix} \quad (6)$$

$$B = \begin{bmatrix} 0 \\ -ex_2 \end{bmatrix} \quad (7)$$

$$C = [1 \quad 0] \quad (8)$$

$$D = [0] \quad (9)$$

#### 4.1 Discrete-Time Controller Design with State Feedback, Setpoint Control, Actual State Observer and Load Estimation

Taking into account a feasible discrete-time system, the state space equations are

$$x_{i+1} = A_d x_i + B_d u_i \quad (10)$$

$$y_i = C x_i. \quad (11)$$

The controllability and observability matrices of the discrete-time system are

$$M_C = [B_d \quad A_d B_d \quad \dots \quad A_d^{n-1} B_d] \quad (12)$$

$$M_O = \begin{bmatrix} C \\ CA_d \\ \dots \\ CA_d^{n-1} \end{bmatrix}, \quad (13)$$

where  $n$  is the dimension of the state variables. Since for every nonzero operating point, the matrices are full rank, the system is controllable and observable in every operating point.

In order to find optimal solutions, we used the LQ control method as state feedback to minimize the tumor volume ( $x_I$ ) using the lowest possible control signal. The discrete-time cost function containing the positive definite  $Q$  and  $R$  weighting matrices is

$$J(u) = \sum_{i=1}^T \{x_i^T Q x_i + u_i^T R u_i\} \quad (14)$$

As our aim was to minimize the square of the output ( $x_I^2 = y^2$ ), the  $Q$  matrix is the following:

$$Q = C^T C. \quad (15)$$

The sought  $K$  feedback matrix of the discrete-time LQ problem can be found using the  $P$  solution of the Discrete Control Algebraic Ricatti Equation (DARE):

$$K = \left( R + B_d^T P B_d \right)^{-1} B_d^T P A_d \quad (16)$$

$$P = A_d^T P A_d - \left( A_d^T P B_d \right) \left( R + B_d^T P B_d \right)^{-1} \left( B_d^T P A_d \right) + Q. \quad (17)$$

For setpoint control, we assume that the reference signal is constant. The control structure is needed to be extended by two matrices ( $N_x$  and  $N_u$ ) in order to use nonzero reference signal. The values of these matrices can be calculated as follows:

$$\begin{pmatrix} N_x \\ N_u \end{pmatrix} = \begin{bmatrix} A_d - I & B_d \\ C & 0 \end{bmatrix}^{-1} \begin{pmatrix} 0_{n \times m} \\ I_m \end{pmatrix}, \quad (18)$$

where  $n$  is the dimension of the state variables, while  $m$  is the dimension of the inputs (and outputs).

As the vascular volume is non-measurable, we designed an actual state observer to estimate this state variable. We have verified that the matrix  $M_o A_d$  is full rank, thus the discrete-time system is observable with an actual observer described by the following difference equation:

$$\hat{x}_i = F \hat{x}_{i-1} + G y_i + H u_{i-1}. \quad (19)$$

The  $F$ ,  $H$  and  $G$  parameter matrices of the observer can be calculated as follows:

$$F = A_d - G C A_d \quad (20)$$

$$H = B_d - G C B_d \quad (21)$$

$$G = \left( e_n^T M_c^{-1} \left( A_d^T, A_d^T C_d^T \right) \varphi_F \left( A_d^T \right) \right)^T, \quad (22)$$

where  $\varphi_F(A_d^T)$  refers to the characteristic polynomial of the matrix  $F$  evaluated at the matrix  $A_d^T$ .

Assuming that a disturbance reduced to the input of the system can occur (load change), we designed load estimation as well. The system was extended by the disturbance modeled as a constant state-variable that adds up to the input of the original model. The state feedback and the setpoint control were designed for the original system; however, the actual state observer was designed for the extended system. As a consequence, the difference equation of the state observer is

$$\begin{pmatrix} \hat{x}_i \\ \hat{x}_{d_i} \end{pmatrix} = \tilde{F} \begin{pmatrix} \hat{x}_{i-1} \\ \hat{x}_{d_{i-1}} \end{pmatrix} + \tilde{G} y_i + \tilde{H} u_{i-1}, \quad (23)$$

where  $\hat{x}_d$  is the estimation of the disturbance.

Figure 2 depicts the whole block diagram of the closed-loop discrete-time control system containing state feedback, setpoint control, actual state observer and load estimation. Please note that saturation is used before the input of the tumor model in order to avoid negative or too high input values due to physiological aspects.

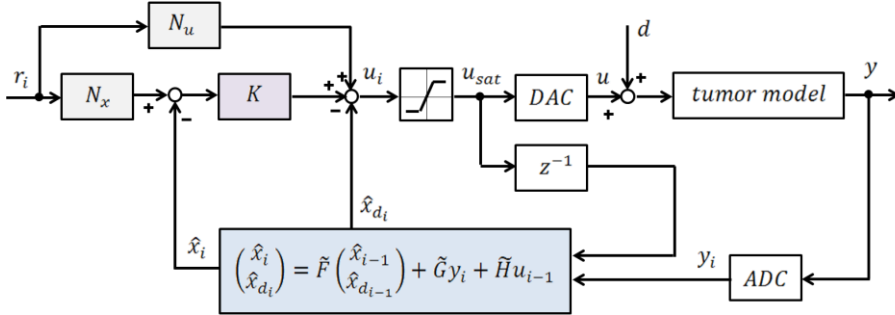

Figure 2

Block diagram of the discrete-time control containing state feedback, setpoint control, actual state observer and load estimation

## 4.2 Simulation Results of the Discrete-Time Controller-based Treatments

Using discrete-time controller, the treatment can contain bolus doses, low-dose metronomic parts and continuous periods as well. In order to get comparable results with the protocol based therapies, the treatment period was chosen to be 15 days. Parameters of the discrete-time controllers were chosen according to [21]. The operating point of the linearization is  $x_1 = x_2 = 10 \text{ mm}^3$ , the  $R$  weighting matrix used in the design of the LQ control is 1. In order to get steady state tumor volumes close the protocol based cancer therapies' values, the reference signal is  $13000 \text{ mm}^3$ . Since protocol based cancer therapies do not have disturbance, the disturbance is 0% in the case of discrete-time controllers. Three different scenarios were examined in the light of the saturation level (left side of Figure 3).



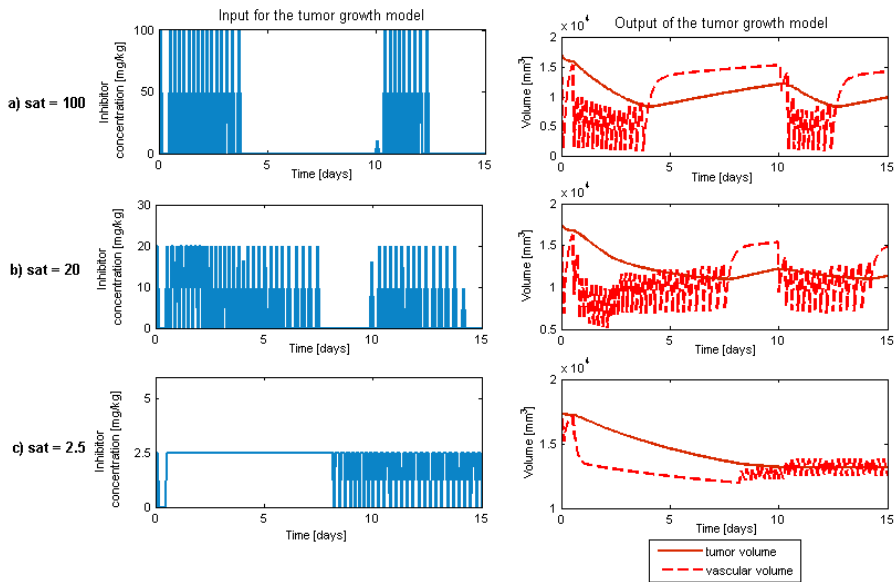

Figure 3

Discrete-time controller based therapies (treatment period is 15 days)

Parameters: operating point:  $10 \text{ mm}^3$ ;  $R$ : 1; reference signal:  $13000 \text{ mm}^3$ ; disturbance: 0%.

a) Therapy C1: saturation =  $100 \text{ mg/kg}$

Total inhibitor concentration:  $138 \text{ mg/kg}$ , steady state tumour volume:  $9870 \text{ mm}^3$ .

b) Therapy C2: saturation =  $20 \text{ mg/kg}$

Total inhibitor concentration:  $56 \text{ mg/kg}$ , steady state tumour volume:  $11360 \text{ mm}^3$ .

c) Therapy C3: saturation =  $2.5 \text{ mg/kg}$

Total inhibitor concentration:  $30 \text{ mg/kg}$ , steady state tumour volume:  $13153 \text{ mm}^3$ .

*Therapy C1 (sat = 100).* The saturation level was chosen to be the maximum tolerated dose (*Therapy P1*). The control signal mostly contains MTD boluses; the administered boluses have lower amplitude only in a few cases. The treatment contains 3 rest periods, the longer one is approximately 6.5 days and it appears in the middle of the therapy.

*Therapy C2 (sat = 20).* This therapy has the same saturation level as *Therapy P2 (BD)*. Due to the lower saturation level compared to *Therapy C1*, this treatment has shorter rest periods; however, the characteristics of the treatments are similar. In the beginning of the therapy, bolus doses follow each other frequently for approximately 7.5 days, and in some cases the boluses are smaller than the level of saturation.

*Therapy C3 (sat = 2.5).* Finally, the saturation level was chosen to be equal to the input of the continuous infusion therapy (*Therapy P3*). The resulting treatment contains only one rest period in the very beginning of the treatment. After that a continuous administration can be obtained for approximately 8 days, which is

followed by a phase where bolus doses follow each other frequently (the amplitude of these boluses is the saturation level in every case).

The right side of Figure 3 depicts the outputs of the tumor growth model, using *Therapy C1* - *Therapy C3* as inputs. Using *Therapy C1*, the total inhibitor concentration is 138 mg/kg, which is the highest total drug administration among the discrete-time controller based therapies. The achieved “steady state”<sup>1</sup> tumor volume is 9870 mm<sup>3</sup> (since at the end of the treatment, an undershoot can be observed). The total inhibitor concentration in *Therapy C2* is 56 mg/kg, which is substantially lower in comparison with *Therapy C1*; however the steady state tumor volume is comparable (11360 mm<sup>3</sup>). Finally, *Therapy C3* has resulted in the lowest total inhibitor concentration (30 mg/kg), and the achieved steady state tumor volume is 13153 mm<sup>3</sup> in this case.

## Conclusions

The efficacy of the therapies are compared and evaluated based on the achieved total inhibitor concentrations and steady state tumor volumes (Figure 4). During the protocol based therapies, the same amount of inhibitor was administered in total. As a consequence, the comparison is quite trivial: the smaller the steady state tumor volume, the better the therapy. Bolus doses with maximum tolerated dose (BD MTD) is the less effective treatment; bolus doses with lower boluses (BD) and low-dose metronomic regimen (LDM) are better; however, the best method is the continuous infusion therapy (cont) from the protocol based therapies. Nevertheless, discrete-time controller based therapies show better performance regardless of the saturation value. The choice between these therapies depends on the medical preferences and constraints. Having a patient who can tolerate MTD, and knowing that the aim is the fastest tumor reduction, we have to choose 100 mg/kg saturation (sat = 100). If we would like to find a trade-off solution, 20 mg/kg saturation (sat = 20) is the most appropriate choice. However, if slower tumor reduction is desired and/or patient does not tolerate the inhibitor well, our choice is the 2.5 mg/kg saturation level (sat = 20).

---

<sup>1</sup> In fact, in most of the cases the output of the tumor growth model does not reach the steady state at the end of the simulation; however, as we would like to express the effectiveness of the control in terms of tumor reduction, we use the “steady state” for the final state of the investigated control and we specify its value.

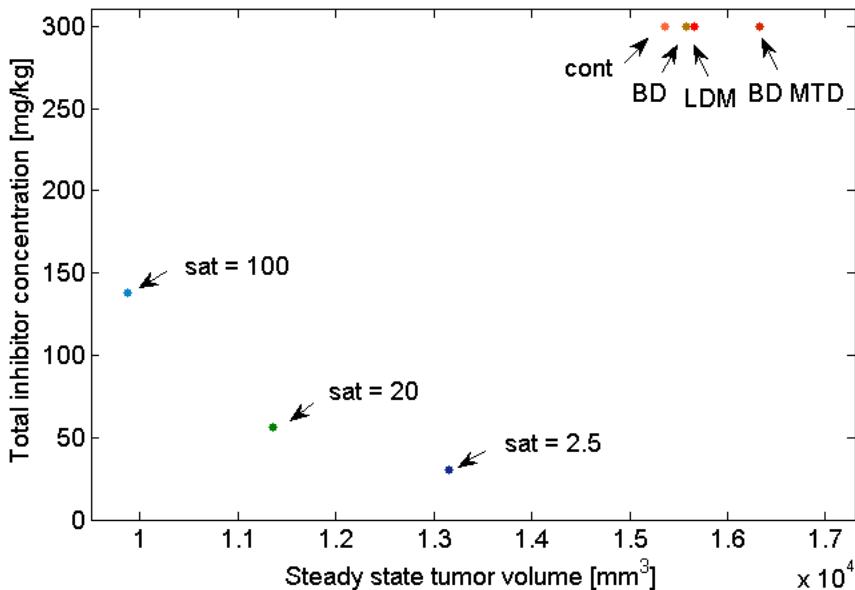

Figure 4

Comparison of the therapies as functions of total inhibitor concentration and steady state tumour volume

Protocol based therapies: bolus doses with maximum tolerated dose (BD MTD), bolus doses (BD), low-dose metronomic regimen (LDM), continuous infusion therapy (cont). Discrete controller based therapies: saturation: 100 mg/kg (sat = 100), saturation: 20 mg/kg (sat = 20), saturation: 2.5 mg/kg (sat = 2.5).

### Acknowledgement

This project has received funding from the European Research Council (ERC) under the European Union's Horizon 2020 research and innovation programme (grant agreement No 679681).

### References

- [1] J. H. Distler, A. Hirth, M. Kurowska-Stolarska, R. E. Gay, S. Gay, O. Distler, "Angiogenic and Angiostatic Factors in the Molecular Control of Angiogenesis", *The Quarterly Journal of Nuclear Medicine*, Vol. 47(3), pp. 149-161, 2003
- [2] N. Ferrara, "Vascular Endothelial Growth Factor and the Regulation of Angiogenesis", *Recent Prog Horm Res*, Vol. 55, pp. 15-35, discussion 35-36, 2000
- [3] A. L. Harris, "Angiogenesis as a New Target for Cancer Control", *European Journal of Cancer Supplements*, Vol. 1, pp. 1-12, 2003

- 
- [4] S. Saha, M. K. Islam, J. A. Shilpi, S. Hasan, "Inhibition of VEGF: a Novel Mechanism to Control Angiogenesis by Withania Somnifera's Key Metabolite Withaferin A", *In Silico Pharmacol*, Vol. 29, pp. 1-11, DOI: 10.1186/2193-9616-1-11, eCollection 2013
- [5] O. Distler, M. Neidhart, R. E. Gay, S. Gay, "The Molecular Control of Angiogenesis", *International Reviews of Immunology*, Vol. 21(1), pp. 33-49, 2002
- [6] P. Hahnfeldt, D. Panigrahy, J. Folkman, and L. Hlatky, "Tumor Development under Angiogenic Signaling: A Dynamical Theory of Tumor Growth, Treatment Response, and Postvascular Dormancy", *Cancer Research*, Vol. 59, pp. 4770-4775, 1999
- [7] D. A. Drexler, L. Kovács, J. Sápi, I. Harmati, Z. Benyó, "Model-based Analysis and Synthesis of Tumor Growth under Angiogenic Inhibition: a Case Study." *IFAC WC 2011 – 18<sup>th</sup> World Congress of the International Federation of Automatic Control*, pp. 3753-3758, August 2011, Milano, Italy
- [8] J. Sápi, D. A. Drexler, I. Harmati, Z. Sápi, L. Kovács, "Linear State-Feedback Control Synthesis of Tumor Growth Control in Antiangiogenic Therapy," *SAMI 2012 – 10<sup>th</sup> IEEE International Symposium on Applied Machine Intelligence and Informatics*, pp. 143-148, January 2012, Herlany, Slovakia
- [9] J. Sápi, D. A. Drexler, I. Harmati, Z. Sápi, L. Kovács, "Qualitative Analysis of Tumor Growth Model under Antiangiogenic Therapy – Choosing the Effective Operating Point and Design Parameters for Controller Design," *Optimal Control Applications and Methods*, Article first published online: 9 SEP 2015, DOI: 10.1002/oca.2196
- [10] D. A. Drexler, J. Sápi, A. Szeles, I. Harmati, A. Kovács, L. Kovács, "Flat Control of Tumor Growth with Angiogenic Inhibition", *SACI 2012 – 6<sup>th</sup> IEEE International Symposium on Applied Computational Intelligence and Informatics*, pp. 179-183, May 2012, Timisoara, Romania
- [11] D. A. Drexler, J. Sápi, A. Szeles, I. Harmati, L. Kovács, "Comparison of Path Tracking Flat Control and Working Point Linearization Based Set Point Control of Tumor Growth with Angiogenic Inhibition", *Scientific Bulletin of the "Politehnica" University of Timisoara, Transactions on Automatic Control and Computer Science*, Vol. 57 (71):(2), pp. 113-120, 2012
- [12] A. Szeles, D. A. Drexler, J. Sápi, I. Harmati, L. Kovács, "Study of Modern Control Methodologies Applied to Tumor Growth under Angiogenic Inhibition", *IFAC WC 2014 – 19<sup>th</sup> World Congress of the International Federation of Automatic Control*, pp. 9271-9276, August 2014, Cape Town, South Africa
-

- 
- [13] A. Szeles, J. Sápi, D. A. Drexler, I. Harmati, Z. Sápi, and L. Kovács, "Model-based Angiogenic Inhibition of Tumor Growth using Modern Robust Control Method", *IFAC BMS 2012 – 8<sup>th</sup> IFAC Symposium on Biological and Medical Systems*, pp. 113-118, August 2012, Budapest, Hungary
- [14] J. Sápi, D. A. Drexler, L. Kovács, "Parameter Optimization of  $H_{\infty}$  Controller Designed for Tumor Growth in the Light of Physiological Aspects", *CINTI 2013 – 14<sup>th</sup> IEEE International Symposium on Computational Intelligence and Informatics*, pp. 19-24, November 2013, Budapest, Hungary
- [15] L. Kovács, A. Szeles, J. Sápi, D. A. Drexler, I. Rudas, I. Harmati, Z. Sápi, "Model-based Angiogenic Inhibition of Tumor Growth using Modern Robust Control Method", *Computer Methods and Programs in Biomedicine*, Vol. 114, pp. 98-110, 2014
- [16] A. Szeles, D. A. Drexler, J. Sápi, I. Harmati, Z. Sápi, L. Kovács, "Model-based Angiogenic Inhibition of Tumor Growth using Feedback Linearization", *CDC 2013 – 52<sup>nd</sup> IEEE Conference on Decision and Control*, pp. 2054-2059, December 2013, Florence, Italy
- [17] A. Szeles, D. A. Drexler, J. Sápi, I. Harmati, L. Kovács, "Model-based Angiogenic Inhibition of Tumor Growth using Adaptive Fuzzy Techniques", *Periodica Polytechnica: Electrical Engineering and Computer Science*, Vol. 58:(1), pp. 29-36, 2014
- [18] J. Sápi, L. Kovács, D.A. Drexler, P. Kocsis, D. Gajári, Z. Sápi, "Tumor Volume Estimation and Quasi-Continuous Administration for Most Effective Bevacizumab Therapy", *Plos One*, Vol. 10:(11), Paper e0142190. 20 p, 2015
- [19] O. Kisker, CM. Becker, D. Prox, M. Fannon, R. D'Amato, E. Flynn, WE. Fogler, BK. Sim, EN. Allred, SR. Pirie-Shepherd, J. Folkman, "Continuous Administration of Endostatin by Intraperitoneally Implanted Osmotic Pump Improves the Efficacy and Potency of Therapy in a Mouse Xenograft Tumor Model", *Cancer Res*, Vol. 61(20), pp. 7669-7674, 2001
- [20] J. Sápi, D. A. Drexler, L. Kovács, "Comparison of Protocol-based Cancer Therapies and Discrete Controller-based Treatments in the Case of Endostatin Administration", *SMC 2016 - IEEE International Conference on Systems, Man, and Cybernetics*, pp. 3830-3835, October 2016, Budapest, Hungary
- [21] J. Sápi, D. A. Drexler, L. Kovács, "Discrete Time State Feedback with Setpoint Control, Actual State Observer and Load Estimation for a Tumor Growth Model", *SACI 2016 - IEEE 11<sup>th</sup> International Symposium on Applied Computational Intelligence and Informatics*, pp. 111-118, May 2016, Timisoara, Romania